

SEALANTS**RTV408 NEUTRAL CURE SILICONE****PRODUCT NAME**

CRL RTV408

One-Component Silicone Elastomeric Sealant.

PRODUCT DESCRIPTION

CRL RTV408 is a neutral cure, medium modulus silicone sealant. It cures to a tough, flexible rubber when exposed to moisture. Features of RTV408 include:

- Primerless adhesion to the following common building materials: metals, aluminum, stainless steel, chromium, tin, iron, plastics, rigid P.V.C., phenolic resin, glass, ceramic, and most reflective coated glasses
- Fast cure (desirable for many in-house production applications)
- Easy gunnability and tooling
- Available in clear, white, aluminum, bronze, beige, tan, black, and custom colors
- Non-corrosive to all common building components (Including insulating glass)
- Long life expectancy. Cured sealant remains flexible from -65°F to 400°F (-54°C to 204°C) without cracking or becoming brittle
- RTV408 White or Tan contains a fungicide, making the sealant suitable for use in bathrooms, spas, and sanitary applications
- AAMA approved for exterior perimeter sealing compound
- 20 year limited warranty. As with most major silicones, life expectancy is still undetermined (aging tests up to and beyond 25 years have resulted in minimal changes to physical properties).

Extensive material testing has shown that the following substrates must be tested for good adhesion and that a primer may be required—plastics, flexible P.V.C., acrylic resin, natural stone, concrete, and wood.

CRL RTV408 complies with or exceeds the following Federal Specifications:

- TTS-001543A (COM-NBS) Class A, Federal Specification for Silicone Building Sealants
- TTS-00230C (COM-NBS) Class A, Non-Sag Federal Specification for One-Component Sealants
- ASTM C920 Standard Specification for Elastomeric Joint Sealant as Type S, Grade NS, Class 25, Use NT, G, A, and O.
- CAN/CGSB-19.13-M97
- AAMA 808.3-92

LIMITATIONS

CRL RTV408 is not recommended for:

- Concrete and stone expansion joints
- Horizontal decks, patios, driveway or terrace joints where abrasion or physical abuse is encountered
- Sealing submerged joints, particularly where porous surfaces permit water infiltration to the bond surface
- Interior or exterior structural sealing below the waterline in marine applications
- Designs that will be painted after application of the sealant (paint films bridge the sealant, but do not adhere to the sealants)
- Structural glazing. Contact CRL Technical Sales Department for recommendations of the proper sealants for this application
- RTV408 is not approved for food contact or potable water applications. For these applications contact the CRL Technical Sales Department

SURFACE LIMITATIONS

RTV408 Sealant should not be applied to the following surfaces:

- a) Construction materials which may exude oils, resins, plasticizers or solvents. These include, but are not limited to, unfinished or impregnated woods, certain rubber or plastic gaskets and tapes, and failed non-silicone sealants or caulking compounds. **NOTE: WHEN RTV408 SEALANT IS USED IN REMEDIAL WORK, THE FAILED NON-SILICONE CAULK MUST BE TOTALLY REMOVED.**
- b) Unclean or wet surfaces.

7
SEALANTS
 RTV408 Silicone
7
 SEPTEMBER 2005
 (Supersedes August 2002)

CRL
 PROFESSIONAL QUALITY

CRL
 PROFESSIONAL QUALITY

 SEPTEMBER 2005
 (Supersedes August 2002)
7
SEALANTS
 RTV408 Silicone

TECHNICAL DATA

The physical properties of CRL RTV408 Silicone are shown in Table 1.

TABLE 1 - PHYSICAL PROPERTIES	
Property/Test Methods	Value
CURED	
Shore A (Hardness) ASTM D-2240	25
Tensile Strength, ASTM D-412	200 psi
Elongation ASTM D-412	300%
Temperature Resistance	-65° to 400°F (-54°C to +204°C)
Dynamic Movement Capability	±25% After 21 Days Cure
UNCURED	
Flow, Sag or Slump TT-S-001543A	Nil
Tooling/Working Time	8-10 minutes (Varies with Temperature/RH)
Tack Free Time	30 minutes (Varies with Temperature/RH)
Full Adhesion, Days	7-10 (Varies with Temperature/RH)

7
 SEALANTS
 RTV408 Silicone

PRINCIPLES OF JOINT DESIGN:

STANDARD GLAZING AND EXPANSION JOINTS

Figure 1 illustrates why a thin bead of silicone sealant will accommodate more movement than a thick bead.

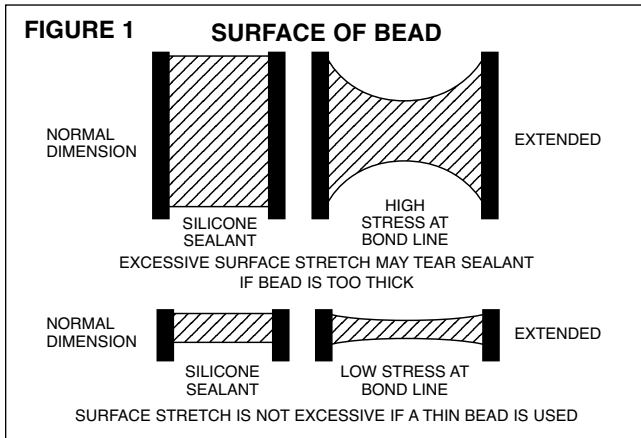

Figure 2 illustrates the use of a bond breaker to prevent three-sided adhesion.

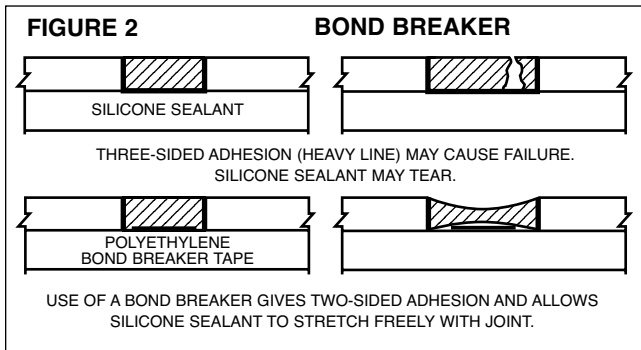
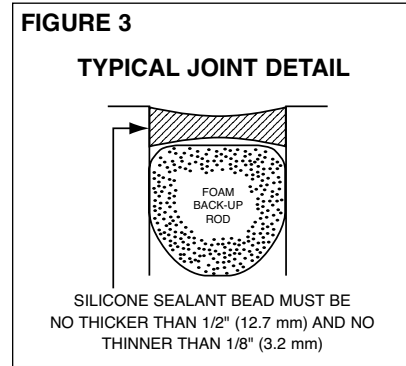

Figure 3 illustrates why silicone sealants should not be installed any thicker than 1/2" (12.7 mm) and no thinner than 1/8" (3.2 mm).



Polyurethane or polyethylene foam rod is the recommended back-up material for deep joints. Polyethylene tape should be used for joints too shallow to allow foam rod. These materials permit application of a thin bead sealant and act as bond breakers which allow silicone sealants to stretch and compress freely with the joint movement.

JOINT DIMENSIONS

Small curtain wall panels and lites should allow a minimum width of 1/4" (6.3 mm) for the sealant bead. Larger panels and lites, or those in which a great deal of movement is expected, should allow a minimum width of four times the expected movement.

Lap shear joints should have a bead width which is equal to, or greater than, the total anticipated movement.

INSTALLATION:

CLEANING

- Clean all joints and glazing area by removal of foreign matter and contaminants such as oil, dust, grease, frost, water, surface dirt, old sealants or glazing compounds, and any protective coating.
- Porous substrates should be cleaned where necessary by grinding, saw cutting, blast cleaning (sand or water), mechanical abrading or a combination of these methods. This will be required to provide a sound, clean and dry surface for sealant application. Dust, loose particles, etc., should be blown out of joints with oil free compressed air, or vacuum cleaned.
- Metal, glass, and plastic surfaces should be cleaned by a solvent procedure or by mechanical means.

CRL
 PROFESSIONAL QUALITY
 SEPTEMBER 2005
 (Supersedes August 2002)

7
 SEALANTS
 RTV408 Silicone

SEPTEMBER 2005
 (Supersedes August 2002)
CRL
 PROFESSIONAL QUALITY

- Detergent or soap and water cleaning treatments are not recommended. Protective films must be removed by a solvent recommended by the manufacturer of the component or other means which leave no residue. In all cases where used, solvents shall be applied with one clean cloth or lint-free paper towel, and then wiped clean with a second cloth or towel. Cleaning solvents should not be allowed to air dry or evaporate without wiping. Architectural coatings, paints, and plastics shall be cleaned with a solvent approved by the manufacturer of that product.

- Cleaning of all surfaces should be done on the same day in which the sealant is applied.
CAUTION: SOLVENTS MAY BE FLAMMABLE AND TOXIC.

PRIMING

When required, primers must be applied according to manufacturer's printed instructions. Priming is not usually required on glass, coated glasses, most plastics, and most metals. A bead of silicone sealant applied to the material surface at the job site or manufacturing location to test adhesion prior to general job use is always recommended.

It is the responsibility of the sealant applicator and concerned parties to check the adhesion of the cured sealant on representative test joints on the project site prior to and during the application of the sealant.

MASKING

Areas adjacent to joints should be masked to assure neat sealant lines. Do not allow masking tape to touch the clean surfaces to which the silicone is to adhere. Tooling should be completed in one continuous stroke immediately after sealant application and before a skin forms. Masking should be removed immediately after tooling.

APPLICATION

- Install backup material or joint filler, setting blocks, spacer shims, and tapes as specified.
- Apply CRL RTV408 Silicone with hand gun or pressure equipment according to FGMA standards in a continuous operation using a positive pressure adequate to properly fill and seal the joint. Tool or strike the sealant with light pressure to spread the material against the backup material and the joint surfaces. A tool with concave profile is recommended to keep the sealant within the joint.
- In glazing, tool the sealant applied at the sill so rain, melting snow, and cleaning solutions will not pool.
- CRL RTV408 Silicone can be applied at extremely low outdoor temperatures provided that surfaces are clean, dry, and frost-free. As a general rule, condensation should not be a problem above 40°F (4°C). The silicone will typically cure slower at lower temperatures. Do not apply when surface temperatures exceed 122°F (50°C).

- Excess sealant should be wiped clean from glass, metal, and plastic surfaces while still uncured and followed with a commercial solvent such as xylol, toluol, or methyl ethyl ketone. CRL Silicone Clean Up Spray, Cat. No. 0S2 cleans uncured silicone sealant. Should sealant accidentally contact and begin to cure on adjacent porous surfaces, the excess sealant should be allowed to progress throughout the initial cure. It should then be removed by abrasion or other mechanical means.

CURED SEALANT IS USUALLY VERY DIFFICULT TO REMOVE WITHOUT ALTERING OR DAMAGING THE SURFACE TO WHICH IT HAS BEEN MISAPPLIED. CRL CAT. NO. 0S2 SILICONE CLEANER/SURFACE PREP MAY ASSIST CURED SEALANT REMOVAL IN MANY CASES.

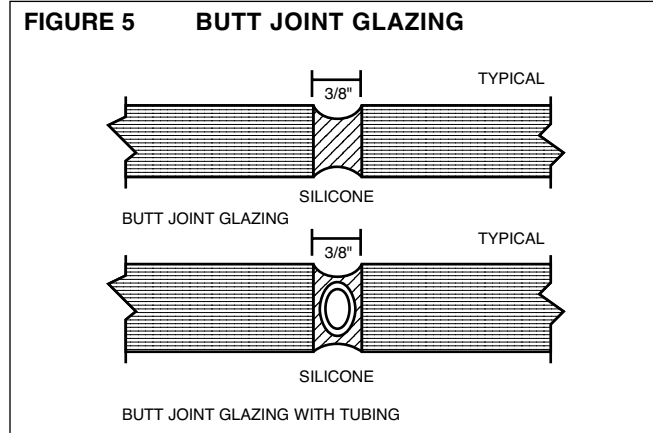
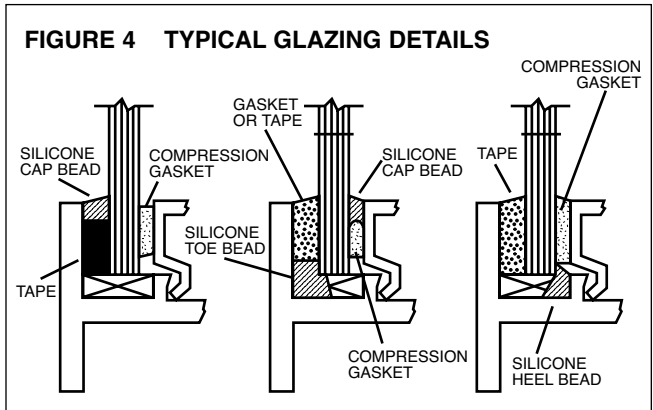

ESTIMATING REQUIREMENTS

APPROX. LINEAR FEET PER CARTRIDGE								
Depth, Inches	Joint Width, Inches							
	1/8"	1/4"	3/8"	1/2"	3/4"	1"	1-1/2"	
	1/8"	96	48	32	24	16	12	8
1/4"	48	24	16	12	8	6	4	
3/8"	32	16	11	8	6	4	3	

APPROX. LINEAR FEET PER GALLON									
Depth, Inches	Width, Inches								
	1/16"	1/8"	1/4"	3/8"	1/2"	5/8"	3/4"	1"	
	1/16"	4928	2464	1232	821	616	493	411	307
1/8"	—	1232	616	411	307	246	205	154	
3/16"	—	—	411	275	205	164	137	103	
1/4"	—	—	307	205	154	123	103	77	
3/8"	—	—	—	137	103	82	68	51	
1/2"	—	—	—	103	77	62	51	39	

MAINTENANCE

No maintenance should be needed. If CRL RTV408 Silicone Sealant becomes damaged, replace damaged portion. Clean surfaces in damaged area and repair with fresh CRL RTV408 Silicone Sealant.

7
SEALANTS
RTV408 Silicone

CRL
PROFESSIONAL QUALITY
SEPTEMBER 2005
(Supersedes August 2002)

PRECAUTION

Uncured sealant may irritate the eyes. Avoid contact with eyes and skin. Contact lens wearers take appropriate precautions. IN CASE OF CONTACT, FLUSH EYES WITH WATER. CALL A PHYSICIAN. Remove from skin with dry cloth or paper towel. A Material Safety Data Sheet for this product can be viewed at crlaurence.com.

KEEP OUT OF REACH OF CHILDREN.

PACKAGING

RTV408 Silicone Sealant is packed in 10.3 fluid ounce high density polyethylene cartridges: 30 cartridges per case, which fit a cartridge caulking gun. Also available in 4.5 gallon pails and 48 gallon drums.

SHELF LIFE/STORAGE

RTV408 Silicone Sealant has a shelf life of 12 months. Store at or below 80°F (27°C). Dispose of empty containers in accordance to federal, state, and local regulations.

WARRANTY LIMITATIONS

The warranty specifically excludes sealant failure due to:

1. Appearance changes due to deposits of dirt and other materials.
2. Decomposition of the underlying substrates.
3. Excess movement of the structure which exceeds published specification for movement caused by building settlement, design error, or construction error.
4. Mechanical damage caused by external sources.
5. Natural disasters such as fires, lightning, earthquakes, tornadoes or hurricanes.

CRL
PROFESSIONAL QUALITY
SEPTEMBER 2005
(Supersedes August 2002)

7
SEALANTS
RTV408 Silicone

TECHNICAL SERVICE

Complete technical information and literature is available from C.R. Laurence Co., Inc. Any technical advice furnished by the company or any representative of the company concerning any use or application of any sealant is believed to be reliable, but the company makes no warranty, expressed or implied, for any use or application for which such advice is furnished.

LIMITED WARRANTY NOTICE

CRL and its manufacturer warrant our products to be of good quality and will replace or, at our election, refund the purchase price of any products proved defective. Satisfactory results depend not only upon quality products but also upon many factors beyond our control in the application process. Therefore, except for such replacement or refund CRL and its manufacturers make no warranty or guarantee, expressed or implied, including warranties of fitness or merchantability, respecting its products. CRL and its manufacturers shall have no other liability with respect thereto. User shall determine the suitability of the product for his intended use and assume all risks and liability in connection therewith. Any authorized change in the printed recommendations concerning the use of our products must bear the signature of the CRL Product Manager.

COOPERATIVE TESTING

Materials submitted for testing should be sent to:
 C.R. Laurence Co., Inc.
 Technical Sales Department
 PO Box 58923
 Los Angeles, CA 90058-0923

This program is intended to eliminate potential field problems by pretesting CRL construction sealants with samples of the building materials on which the sealant will be applied. The test will aid in determining the proper surface preparation method, effective solvents for cleaning, and whether priming is necessary to achieve optimum adhesion. Following this procedure will remove many of the unknown variables which affect field success.

Test samples of substrates should be identified as to manufacturer, origin, designed use, building project, person and firm originating the request. Appropriate sketches or drawings showing the intended use can be helpful.

C.R. LAURENCE CO., INC. LOCATIONS

United States

Los Angeles, California
 2503 E Vernon Avenue
 Los Angeles, CA 90058-1897
 Phone: (323) 588-1281
 Fax: (323) 581-6522

New York City Area
 211 County Avenue
 Secaucus, NJ 07094-2006
 Phone: (201) 770-1077
 Fax: (201) 770-1599

Cleveland Area
 31600 Carter Street
 Solon, OH 44139-3551
 Phone: (440) 248-0003
 Fax: (440) 248-0120

CRL Manufacturing
 2100 E. 38th Street,
 Los Angeles, CA 90058-1617
 Phone: (323) 588-1281
 Fax: (323) 232-2240

Dallas, Texas
 2080 Lone Star Drive
 Dallas, TX 75212-6390
 Phone: (214) 634-7305
 Fax: (214) 631-6519

Boston Area
 97 Robert Treat Paine Drive
 Taunton, MA 02780-1267
 Phone: (508) 880-5600
 Fax: (508) 880-5775

Philadelphia Area
 1511 Lancer Drive
 Moorestown, NJ 08057-4232
 Phone: (856) 727-1022
 Fax: (856) 727-3299

Europe
C.R. Laurence Europe GmbH
 Bruehstrasse 3
 D-74206 Bad Wimpfen
 Germany
 Phone: 49-7063-933-633
 Fax: 49-7063-933-634

Chicago Area
 1501 Tonne Road
 Elk Grove Village, IL
 60007-5069
 Phone: (847) 437-8320
 Fax: (847) 437-8447

Orlando, Florida
 6950 Presidents Drive
 Orlando, FL 32809-5668
 Phone: (407) 857-7900
 Fax: (407) 857-7766

Phoenix, Arizona
 640 S. 54th Avenue
 Phoenix, AZ 85043-4731
 Phone: (602) 269-7500
 Fax: (602) 269-7600

San Francisco / Oakland Area
 33200 Dowe Avenue
 Union City, CA 94587-2013
 Phone: (510) 475-1000
 Fax: (510) 475-1404

Denver, Colorado
 4770 Joliet Street
 Denver, CO 80239-2513
 Phone: (303) 373-9988
 Fax: (303) 373-0884

Las Vegas, Nevada
 4120 Sobb Avenue
 Las Vegas, NV 89118-6857
 Phone: (702) 253-0211
 Fax: (702) 253-0311

Atlanta, Georgia
 600 Wharton Drive
 Atlanta, GA 30336-4040
 Phone: (404) 696-3445
 Fax: (404) 696-3386

Seattle Area
 23000 64th Avenue SW
 Kent, WA 98032-1838
 Phone: (253) 850-5800
 Fax: (253) 813-1818

Houston, Texas
 4420 Windfern Road
 Houston, TX 77041-8918
 Phone: (713) 462-6300
 Fax: (713) 462-6306

 **CRL Canada** 

Vancouver Area
 11920 Horseshoe Way
 Richmond, BC V7A 4V5
 Phone: (604) 448-9344
 Fax: (604) 448-9322

Montreal Area
 8200 Rue Des Bâtisseurs
 Anjou, QC H1J 3B3
 Phone: (514) 352-3300
 Fax: (514) 352-1017

Toronto Area
 65 Tigi Court
 Concord, ON L4K 5E4
 Phone: (905) 303-7966
 Fax: (905) 303-7965

Calgary, Alberta
 4200 116 Avenue SE
 Calgary, AB T2Z 4B5
 Phone: (403) 250-5783
 Fax: (403) 291-3260

SEALANTS
 RTV/408 Silicone

7

SEPTMBER 2005
 (Supersedes August 2002)

 PROFESSIONAL QUALITY

 PROFESSIONAL QUALITY

SEPTEMBER 2005
 (Supersedes August 2002)

7
 SEALANTS
 RTV/408 Silicone